



# BEARING & TOOL CENTRE



## Head Office

1<sup>st</sup> Floor, Vyapar Bhavan, Kadia Kui,  
Relief Road, Ahmedabad - 380001.  
Ph:- 079 - 22160386, 65254835, 22134835  
Mobile : 7819819941, 9375706649

## Ahmedabad Branch

GF-B-14, Jayraj Complex, Nr. Soni ni Chawl,  
Odhav, Ahmedabad - 382415.  
Ph:- 079 - 22890202, 65458950, 65404657, 65400202  
Mobile : 7878825197, 7819819938, 9375706648

Website : [www.bearingtoolcentre.com](http://www.bearingtoolcentre.com), [www.bearingtoolscentre.com](http://www.bearingtoolscentre.com) | Email : [info@bearingtoolcentre.com](mailto:info@bearingtoolcentre.com)

## Our Sister Concern : RELIEF SERVICE CENTRE

Repairs, Removal of Jaw Error, Bore Gauge Extension, Instrument Modifications & Spares

### Quotation

72 | Bench Centre – As per IS 5980 – 1978 – Grade I – with Cert.

Centre Distance	D%	300	300	500	500	750	1000	1000	1250	1250	1500	1500
Centre Height		125	160	160	200	160	160	200	160	200	160	200
Luthra Rs.		16000	17250	19750	21000	24750	29000	30500	36000	37250	46000	47250
Catalog		Page-3 to 10	Page-3 to 10	Page-3 to 10	Page-3 to 10	Page-3 to 10	Page-3 to 10	Page-3 to 10	Page-3 to 10	Page-3 to 10	Page-3 to 10	Page-3 to 10
Black Hawk Rs.	18	18758	19255	29707	31083	36447	51428	52722				
Code		A076	B076	A078	A079	A080	A082	A083				
Catalog		Page-12,13	Page-12,13	Page-12,13	Page-12,13	Page-12,13	Page-12,13	Page-12,13	Page-12,13	Page-12,13	Page-12,13	Page-12,13
NABL Traceable Rs				900	900	900	1580	1580	1580	1580	1580	1580
NABL Accrediat Rs.				1200	1200	1200	2100	2100	2100	2100	2100	2100

\*\* D = Discount

72 – 1 | Bench Centre- Jafuji make – As per IS 5980 – 1978 – Grade I – with Cert.

S.N. I	Code No.	Product	Rs. Each	NABL TraceableRs	Catalog	NABL Accrediat Rs
		Jafuji Bench Centre	Price List			
1.	MBC – 2010	Mini Bench Centre	8125		Page-14	
2.	BC – 3010	Bench Centre 300 x 125mm	26500		Page-14	
3.	BC – 3020	Bench Centre 500 x 125mm	34200	900	Page-14	1200
4.	BC – 3030	Bench Centre 500 x 160mm	41000	900	Page-14	1200
5.	BC – 3040	Bench Centre 500 x 200mm	44750	900	Page-14	1200
6.	BC – 3050	Bench Centre 750 x 160mm	48800	900	Page-14	1200
7.	BC – 3060	Bench Centre 750 x 200mm	53300	1580	Page-14	1200
8.	BC – 3070	Bench Centre 1000 x 160mm	56500	1580	Page-14	2100
9.	BC – 3080	Bench Centre 1000 x 200mm	60000	1580	Page-14	2100
10.	BC – 3090	Bench Centre 1250 x 160mm	65100	1580	Page-14	2100
11.	BC – 3100	Bench Centre 1250 x 200mm	68500	1580	Page-14	2100
12.	BC – 3120	Bench Centre 1500 x 160mm	72100	1580	Page-14	2100
13.	BC – 3130	Bench Centre 1500 x 200mm	78325	1580	Page-14	2100
14.	BC – 3140	Bench Centre 1500 x 250mm	82800	1580	Page-14	2100
15.	BC – 3150	Bench Centre 2000 x 200mm	145200	1580	Page-14	2100

**Discount 13% on above Jafuji make.**

## **Terms & Conditions –**

- Goods offered - Subject to Prior Sale
- Price Validity: "15 Days from Date of Quotation"
- C.S.T 2% extra against form C. Otherwise 5% without form C For Out of Gujarat Sales only.
- VAT 5% extra for Sales within Gujarat. Prices Ex-Godown Ahmedabad.
- Payment against Proforma Invoice, Packing, Forwarding & Freight extra.
- **Bank Detail** – Kotak Mahindra Bank Ltd.
- **Branch** – Shivranjini
- **Bank IFSC Code** - KKBK 0000 810
- **Bank Account No.** 08102 00000 2689
- Note - While making payment online do mention your Company's name.
- TIN NO 24070901229 , CST No. 24570901229
- We are looking forward to your valued orders.

# LUTHRA MAKE



## PRECISION TOOLS

- Base of the Bench Centre is made of Close Grained Castings and finished to high degree of accuracy by hand scrapping
- The Base of Bench Centre and its heads are artificially Stress Relieved.
- One of the centre is spring loaded to ensure uniform pressure while holding work pieces and easy holding and unloading without disturbing the accuracy of centres.
- Both heads are adjustable to the required position, easy and quick setting of the required distance between centres.
- The heavy duty bed is provided with two T-Slots, parallel to each other.
- Bench Centre is ideal for checking of run-out, concentricity, parallelism and axial runout of components.

### GEAR TESTING ATTACHMENT

- Gear Testing attachment is unique in design and meant for inspecting concentricity and cumulative errors of Gears with respect to gear axis.

**ACCURACY:** Parallelism of centres with base within 0.005mm./300 mm The flatness of base 0.003/300 mm.

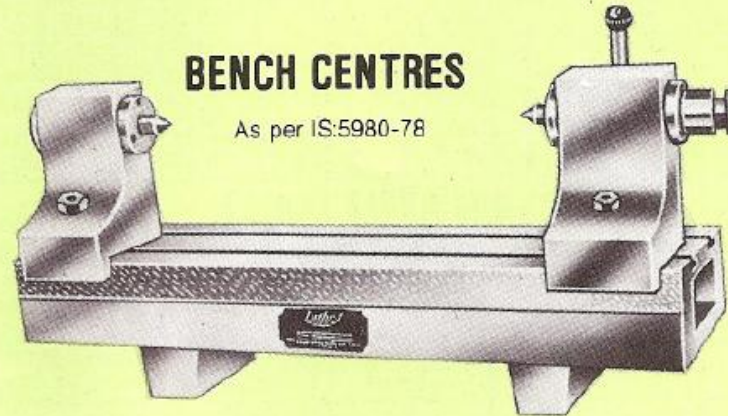

Centre Distance in MM	300, 500, 750, 1000, 1250, 1500, 2000
Centre Height in MM	125, 160, 175, 200, 250, 400

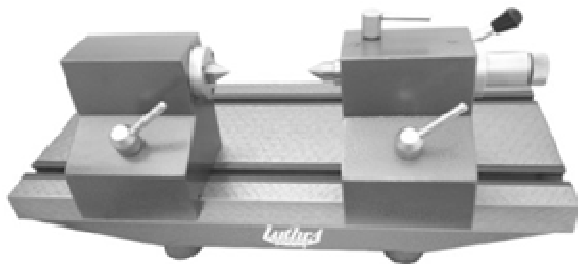

## BENCH CENTRES

As Per IS: 5980-1978

CENTRE DISTANCE (MM)	CENTRE HEIGHT (MM)	GRADE - I PRICES IN INR	GEAR TESTOR (PCD)	FABRICATED STAND WITH LEVELLING SCREWS
300	125	16000.00	8500.00	2700.00
300	160	17250.00	8650.00	2700.00
500	160	19750.00	9150.00	2950.00
500	200	21000.00	9250.00	2950.00
750	160	24750.00	9800.00	4100.00
750	200	26000.00	10250.00	4100.00
1000	160	29000.00	10650.00	4700.00
1000	200	30500.00	11000.00	4700.00
1250	160	36000.00	11500.00	5300.00
1250	200	37250.00	11750.00	5300.00
1500	160	46000.00	12850.00	7150.00
1500	200	47250.00	13400.00	7150.00
2000	200	59500.00	14000.00	7800.00
2000	250	62500.00	14750.00	7800.00

Other Sizes on Request

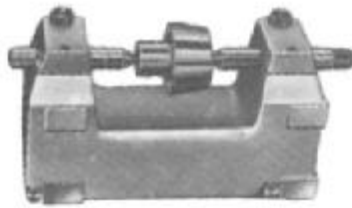

## UNIVERSAL BENCH CENTRE

**VERTICAL CUM HORIZONTAL**

*To be used on Surface Plate only*

<b>CENTRE DISTANCE</b> (MM)	<b>CENTRE HEIGHT</b> (MM)	<b>GRADE -I</b> PRICES IN INR
300	160	20500.00

*Other Sizes on Request*



## C.I. SURFACE PLATES WITH BENCH CENTRE

As per IS 2285-2003 & 5980-78

<b>SIZE OF PLATE</b> (MM)	<b>CENTRE DISTANCE</b> (MM)	<b>CENTRE HEIGHT</b> (MM)	<b>GRADE -I</b> PRICES IN INR	<b>FABRICATED STAND WITH</b> LEVELLING SCREWS
750 x 600	400	125	25750.00	3550.00
1000 x 630	600	160	36000.00	4150.00
1000 x 1000	600	200	55250.00	5300.00
1000 x 1600	1200	160	109500.00	7300.00
1000 x 2000	1600	200	138500.00	8800.00

*Other Sizes on Request*



## GRANITE SURFACE PLATE WITH BENCH CENTRE

*Granite Surface Plates with Cast Iron Heads*

As per IS 7327-2003 & 5980-78

<b>SIZE OF PLATE</b> (MM)	<b>CENTRE DISTANCE</b> (MM)	<b>CENTRE HEIGHT</b> (MM)	<b>GRADE -I</b> PRICES IN INR	<b>FABRICATED STAND WITH</b> LEVELLING SCREWS
630 x 630	300	125	19850.00	3050.00
1000 x 630	600	160	33000.00	4150.00
1000 x 630	800	200	34250.00	4150.00
1000 x 1000	800	200	46500.00	5300.00

*Other Sizes on Request*

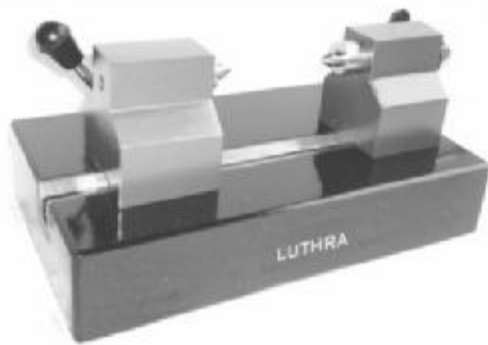

## GRANITE BENCH CENTRES

As Per IS: 5980-1978

<b>CENTRE DISTANCE</b> (MM)	<b>CENTRE HEIGHT</b> (MM)	<b>GRADE -I</b> <i>PRICES IN INR</i>	<b>GEAR TESTOR</b> (PCD)	<b>FABRICATED STAND</b> <i>WITH LEVELING SCREWS</i>
300	125	16250.00	10250.00	2700.00
300	160	17500.00	10250.00	2700.00
500	160	20000.00	12500.00	2950.00
500	200	21250.00	12500.00	2950.00
750	160	24500.00	13500.00	4100.00
750	200	25750.00	13500.00	4100.00

*Other Sizes on Request*



### MINI BENCH CENTRE CAST IRON

*(Spring Loaded)*

<b>CENTRE DISTANCE</b> (MM)	<b>CENTRE HEIGHT</b> (MM)	<b>GRADE -I</b> <i>PRICES IN INR</i>
150	75	5950.00



### MINI BENCH CENTRE GRANITE BASE

*(Spring Loaded)*

<b>CENTRE DISTANCE</b> (MM)	<b>CENTRE HEIGHT</b> (MM)	<b>GRADE -I</b> <i>PRICES IN INR</i>
150	75	6800.00



### VERTICAL BENCH CENTRE

<b>CENTRE DISTANCE</b> (MM)	<b>CENTRE HEIGHT</b> (MM)	<b>GRADE -I</b> <i>PRICES IN INR</i>
500	160	46500.00

*Other Sizes on Request*

## Bench Centres

We offer a vast range of superior quality bench centres, which are extensively used for general inspection work in metrology laboratories and other industries. Our range includes cast iron bench centre, mini bench centre, vertical bench centre, universal bench centre and many other. These bench centres are known for delivering better durability, reliability and performance in the defined operations. Further, we also customize these bench centres as per the specific demands of clients.

Our range of bench centres includes cast iron bench centre, vertical bench centre, mini bench centre cast iron base, mini bench centre granite base, universal bench centre, surface plate with bench centre and bench vise.

### Cast Iron Bench Centre



Gear Testing Attachment Mounted On Bench Centre

## Vertical Bench Centre



 Enlarged View

Size mm	Centre distance mm	Centre Height mm	Accuracy in Microns $\mu\text{m}$
150 x 75	150	75	10

**\*Other Sizes On Request**

## Mini Bench Centre Cast Iron Base

**HOT**

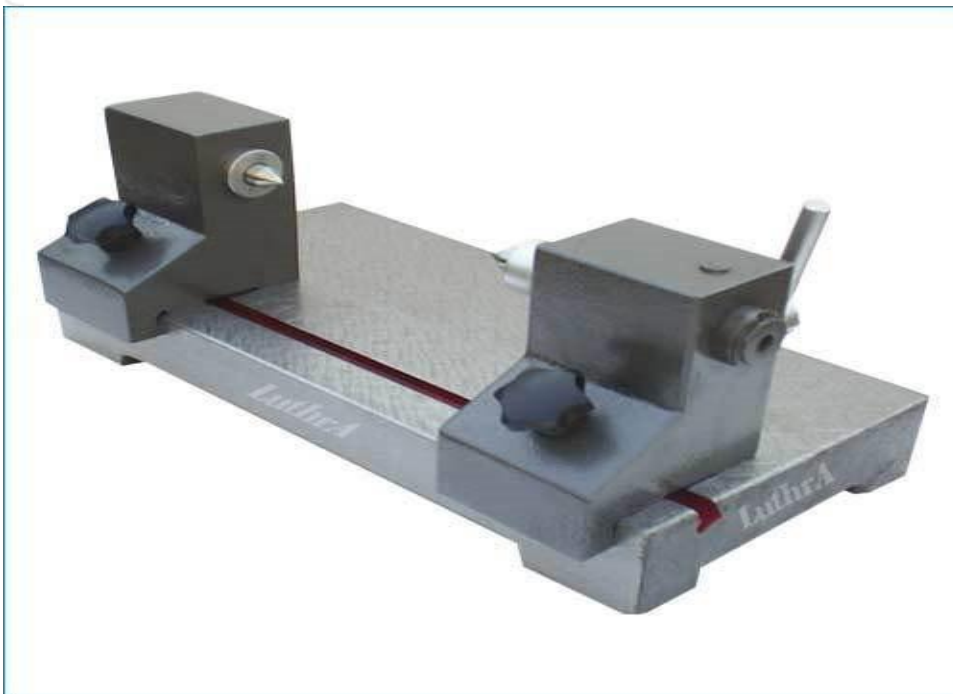

## Mini Bench Centre Granite Base



Each Luthra granite mini bench centre is provided with computerised calibration certificate traceable to NPL (Govt. Of India)

**Standard size and accuracy of Luthra Mini Bench Centre as per IS : 5980-1978, Grade 1**

Size mm	Centre distance mm	Centre Height mm	Accuracy in Microns um
150 x 75	150	75	10

**\*Other Sizes On Request**



## Universal Bench Centre

Universal bench centres are used on calibrated surface plate for checking concentricity, Axis run out, Parallelism. Unique design of universal bench centre allows to check accuracy both horizontally and vertically.

Centres for holding work are hardened and ground and are adjustable to any desired position as per sizes of the component. Each universal bench centre is supplied with computerised calibration certificate traceable to National Physical Laboratory (NPL, Govt. Of India) New Delhi.



### Specifications.

- Centre Distance: 150 mm
- Centre Height : 75 mm

## Surface Plate With Bench Centre



Surface plate with bench centre is the dual combination of surface plate and bench centre, this combined feature make them extremely useful inspection equipment in engineering industry.

**Standard size and accuracy of Surface plate with bench centre as per IS:2285-2003 and IS:5980-1978. Grade - 1**

Size Of Plate mm	Centre Distance mm	Centre Height mm
750 x 600	400	125
1000 x 630	600	160
1000 x 1000	600	200
1000 x 1600	1200	160
1000 x 2000	1600	200

**\*Other Sizes On Request**

**Specifications:**

Model	Sizes mm	Centre Distance mm	Centre Height mm	Co-axiality of Centres Microns um	Parallelism of the axis of the centre With respect to guide ways.
BC-3	300 x 125	300	125	10	10um/300 mm
BC-3	300 x 160	300	160	10	10um/300 mm
BC-5	500 x 160	500	160	15	10um/300 mm
BC-5	500 x 200	500	200	15	15um/300 mm
BC-7	750 x 160	750	160	20	10um/300 mm
BC-7	750 x 200	750	200	40	15um/300 mm
BC-10	1000 x 160	1000	160	20	10um/300 mm
BC-10	1000 x 200	1000	200	40	15um/300 mm
BC-12	1250 x 160	1250	160	20	10um/300 mm
BC-12	1250 x 200	1250	200	40	15um/300 mm
BC-15	1500 x 160	1500	160	20	10um/300 mm
BC-15	1500 x 200	1500	200	40	15um/300 mm
BC-20	2000 x 200	2000	200	40	15um/300 mm
BC-20	2000 x 250	2000	250	40	15um/300 mm
BC-25	2500 x 250	2500	250	40	15um/300 mm
BC-25	2500 x 300	2500	300	40	15um/300 mm
BC-25	2500 x 500	2500	500	60	20um/300 mm

Code No.	Admit Between Centre	Height of Centre	Morse Taper	Mass Kg.
3010	300 mm	125 mm	MT-3	48
3020	500 mm	125 mm	MT-3	76
3030	500 mm	160 mm	MT-3	105
3040	500 mm	200 mm	MT-3	107
3050	750 mm	160 mm	MT-3	131
3060	750 mm	200 mm	MT-3	137
3070	1000 mm	160 mm	MT-3	138
3080	1000 mm	200 mm	MT-3	142
3090	1250 mm	160 mm	MT-3	200
3100	1250 mm	200 mm	MT-3	202
3110	1500 mm	160 mm	MT-3	204
3120	1500 mm	200 mm	MT-3	206
3130	1500 mm	250 mm	MT-3	211

# PRECISION BENCH CENTRE

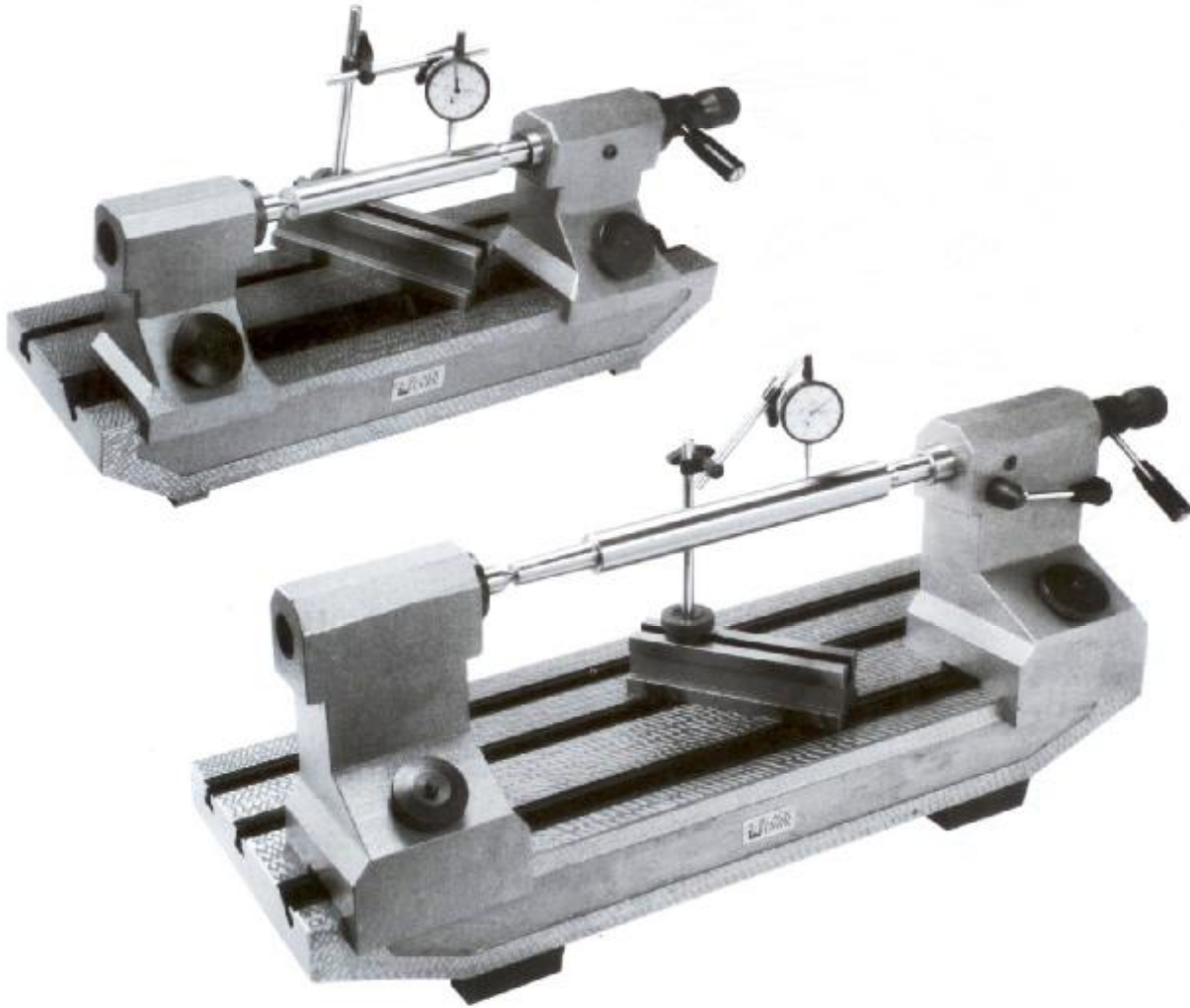

## Features :

- Graded Cast Iron
- Stress relieved working face
- Unique easy removal & mounting mechanism
- Hardened Centres
- Precision Ground
- Aesthetic Finish
- Rugged Construction

*precision professionals*



Model No.	Product Specification (L x B x H) mm	Admit Between Centre (ABC) mm	Height of Centre (HC) mm	Morse Taper	Weight Kgs.
A 076	675 x 200 x 225	300	125	MT - 3	52 Kg
A 077	880 x 300 x 300	500	125	MT - 3	78 Kg
A 078	880 x 300 x 340	500	160	MT - 3	80 Kg
A 079	880 x 300 x 380	500	200	MT - 3	112 Kg
A 080	1130 x 300 x 340	750	160	MT - 3	135 Kg
A 081	1130 x 300 x 380	750	200	MT - 3	142 Kg
A 082	1450 x 300 x 340	1000	160	MT - 3	140 Kg
A 083	1450 x 300 x 380	1000	200	MT - 3	154 Kg

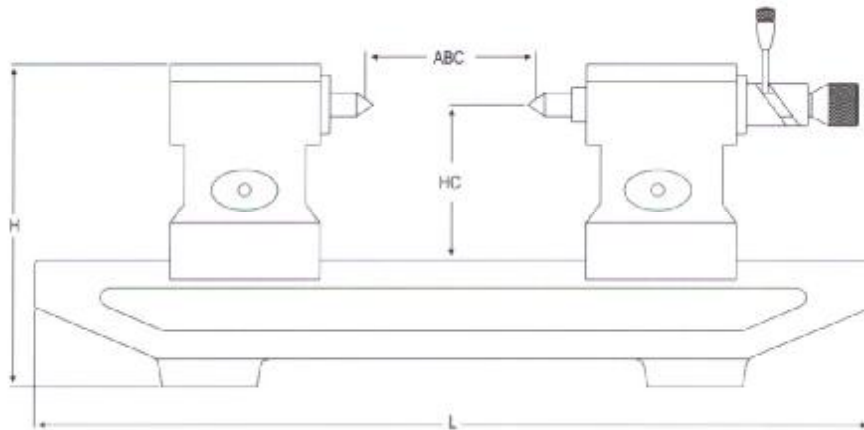

### Precision Bench Centre

Centres : Quality steel of 750 HV.

Co-ordinateed clamping : Fine functional ribs for casting. Pre-loaded spring with length adjustment by screw mechanism

Spring loaded centre on one side.

# JAFUJI MAKE

S.N	Code No.	PRODUCT	PRICE EACH
I		JAFUJI BENCH CENTRE	PRICE LIST
1	MBC - 2010	Mini Bench Centre	8125
2	BC - 3010	Bench Centre 300 x 125 mm	28300
3	BC - 3020	Bench Centre 500 x 125 mm	34200
4	BC - 3030	Bench Centre 500 x 160 mm	41000
5	BC - 3040	Bench Centre 500 x 200 mm	44750
6	BC - 3050	Bench Centre 750 x 160 mm	48800
7	BC - 3060	Bench Centre 750 x 200 mm	53300
8	BC - 3070	Bench Centre 1000 x 160 mm	56500
9	BC - 3080	Bench Centre 1000 x 200 mm	60000
10	BC - 3090	Bench Centre 1250 x 160 mm	65100
11	BC - 3100	Bench Centre 1250 x 200 mm	68500
12	BC - 3120	Bench Centre 1500 x 160 mm	72100
13	BC - 3130	Bench Centre 1500 x 200 mm	78325
14	BC - 3140	Bench Centre 1500 x 250 mm	82800
15	BC - 3150	Bench Centre 2000 x 200 mm	145200

#### Terms & Conditions:

- 1 Delivery : Ex-Works, Hyderabad
- 2 P & F : Packing & Forwarding charges extra
- 3 Sales Tax : (i) At present 2% CST against Form 'C' / Applicable as on billing date  
(ii) At Present 5% VAT / Applicable as on billing date  
(iii) At present 14.5% VAT on Stands / Applicable as on billing date
- 4 Excise Duty : At Present Nil / Applicable as on billing Date
- 5 Payment : Against delivery or documents through Bank for full payment
- 6 Price : Subject to revision without prior notice

**NOTE:** (i) Stands for Surface Plate above size 1000x1000 will be made by 65x65 mm M S Angle