



# BEARING & TOOL CENTRE



## Head Office

1<sup>st</sup> Floor, Vyapar Bhavan, Kadia Kui,  
Relief Road, Ahmedabad - 380001.  
Ph:- 079 - 22160386, 65254835, 22134835  
Mobile : 7819819941, 9375706649

## Ahmedabad Branch

GF-B-14, Jayraj Complex, Nr. Soni ni Chawl,  
Odhav, Ahmedabad - 382415.  
Ph:- 079 - 22890202, 65458950, 65404657, 65400202  
Mobile : 7878825197, 7819819938, 9375706648

Website : [www.bearingtoolcentre.com](http://www.bearingtoolcentre.com), [www.bearingtoolscentre.com](http://www.bearingtoolscentre.com) | Email : [info@bearingtoolcentre.com](mailto:info@bearingtoolcentre.com)

## Our Sister Concern : RELIEF SERVICE CENTRE

Repairs, Removal of Jaw Error, Bore Gauge Extension, Instrument Modifications & Spares

### Quotation

#### 44 | Center Distance Vernier, Graduation 0.02mm – Insize Make

Range-mm	W	C	D %	10-150	10-200	10-300
InsizeRs.	12	N		-----	-----	-----
Code				1292-1501	1292- 2001	1292-3001
Catalog				Page No – 2,3	Page No – 2,3	Page No – 2,3

#### 44 – 1 | Center Distance Vernier, Graduation 0.05mm

Range-mm	W	C	D %	10-150	10-200	10-300
InsizeRs.	12	N		-----	-----	-----
Code				1292-1503	1292- 2003	1292-3003
Catalog				Page No – 2	Page No – 2	Page No – 2

#### 44 – 2 | Digital Offset Centerline Caliper, Graduation 0.01mm / 0.0005”

Range-mm	W	C	D %	10-150	10-200	10-300
InsizeRs.	12	N		12991	15897	18542
Code				1192-150A	1192- 200A	1192-300A
Catalog				Page No – 2	Page No – 2	Page No – 2

\*\*\* W – Warranty , C – Certificate , D- Discount

## Terms & Conditions –

- Goods offered - Subject to Prior Sale
- Price Validity: "15 Days from Date of Quotation"
- C.S.T 2% extra against form C. Otherwise 5% without form C For Out of Gujarat Sales only.
- VAT 5% extra for Sales within Gujarat. Prices Ex-Godown Ahmedabad.
- Payment against Proforma Invoice, Packing, Forwarding & Freight extra.
- **Bank Detail** – Kotak Mahindra Bank Ltd.
- **Branch** – Shivranjini
- **Bank IFSC Code** - KKBK 0000 810
- **Bank Account No.** 08102 00000 2689
- Note - While making payment online do mention your Company's name.
- TIN NO 24070901229 , CST No. 24570901229
- We are looking forward to your valued orders.

# INSIZE MAKE

## OFFSET CENTERLINE VERNIER CALIPER

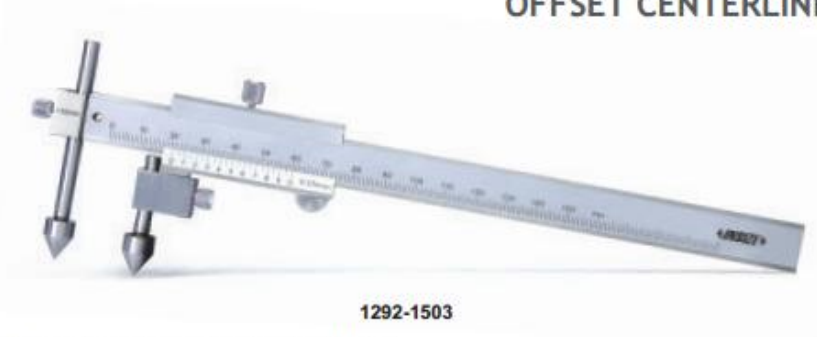

1292-1503

- Measure hole center distance in the same or offset planes
- Made of stainless steel
- Stain chrome plated reading surface

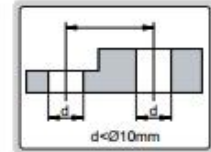

Graduation 0.02mm (mm)			
Code	Range	Accuracy	L
1292-1501	10-150mm	$\pm 0.05\text{mm}$	236
1292-2001	10-200mm	$\pm 0.07\text{mm}$	246
1292-3001	10-300mm	$\pm 0.09\text{mm}$	396

Graduation 0.05mm (mm)			
Code	Range	Accuracy	L
1292-1503	10-150mm	$\pm 0.05\text{mm}$	236
1292-2003	10-200mm	$\pm 0.07\text{mm}$	246
1292-3003	10-300mm	$\pm 0.09\text{mm}$	396

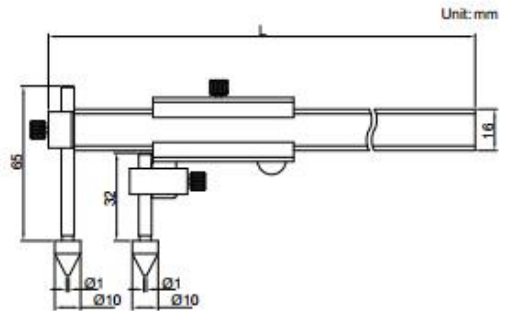

- Measure hole center distance in the same or offset planes
- Resolution: 0.01mm/0.0005"
- Buttons: on/off, set, mm/inch, preset (+, -)
- Automatic power off, move the digital unit to turn on power
- Battery CR2032
- Data output
- Made of stainless steel
- Optional accessory: data output cable (code 7306-20, 7302-SPC5A/SPC5B, 7305-SPC2A)

DATA OUTPUT

## DIGITAL OFFSET CENTERLINE CALIPER



1192-150A

(mm)							
Code	Range	Accuracy	c	$\varnothing D$	L1	L2	L
1192-150A	10-150mm/0.4-6"	$\pm 0.05\text{mm}$	16	10	32	65	236
1192-200A	10-200mm/0.4-8"	$\pm 0.07\text{mm}$	16	10	32	65	286
1192-300A	10-300mm /0.4-12"	$\pm 0.09\text{mm}$	16	10	32	65	396
1192-500A	20-500mm/0.8-20"	$\pm 0.09\text{mm}$	24	20	38	88	686
1192-1000A	30-1000mm/1.2-40"	$\pm 0.12\text{mm}$	31	30	38	88	1242
1192-1500A	30-1500mm/1.2-60"	$\pm 0.15\text{mm}$	31	30	38	88	1745

