



BEARING & TOOL CENTRE



Head Office

1st Floor, Vyapar Bhavan, Kadia Kui,
Relief Road, Ahmedabad - 380001.
Ph:- 079 - 22160386, 65254835, 22134835
Mobile : 7819819941, 9375706649

Ahmedabad Branch

GF-B-14, Jayraj Complex, Nr. Soni ni Chawl,
Odhav, Ahmedabad - 382415.
Ph:- 079 - 22890202, 65458950, 65404657, 65400202
Mobile : 7878825197, 7819819938, 9375706648

Website : www.bearingtoolcentre.com, www.bearingtoolscentre.com | Email : info@bearingtoolcentre.com

Our Sister Concern : RELIEF SERVICE CENTRE

Repairs, Removal of Jaw Error, Bore Gauge Extension, Instrument Modifications & Spares

Quotation

75 | Comparator Stand – Granite and Cast Iron

Graph Datum – Granite - Centrally Mounted – Without Dial					
Size	250 x 150 h 200	250 x 150 h 300	250 x 150 h 200	300 x 300 h 200	300 x 300 h 300
Code	GCS - 1	GCS - 2	GCS - 3	GCS - 4	GCS - 5
Fine Adj.	Yes	Yes	No	Yes	Yes
Rod	Threaded	Threaded	Plain	Threaded	Threaded
Rs.	4070	4400	3630	4680	5040
Catalog	Page No - 3	Page No - 3	Page No - 3	Page No - 3	Page No - 3
Size	300 x 200 h 200	300 x 300 h 200	300 x 300 h 300	150 x 150 h 200	
Code	GCS - 6	GCS - 7	GCS - 8	GCS - 9	
Fine Adj.	No	No	No	No	
Rod	Threaded	Threaded	Threaded	Plain	
Rs.	4290	4680	4950	3300	
Catalog	Page No - 3	Page No - 3	Page No - 3	Page No - 3	Page No - 3

75 - 1 | Comparator Stand – Granite – Luthra - Make - Centrally Mounted – Without Dial

Size	150 x 100 x 50	250 x 150 x 50	300 x 200 x 50	300 x 300 x 50
Code	LGS-1C	LGS-2C	LGS-3C	LGS-4C
Fine Adj. Rs.	3150	4500	5200	5800
Without find Adj. Rs.	2000	3250	3900	4450
Catalog	Page No – 4,5	Page No – 4,5	Page No – 4,5	Page No – 4,5

75 – 2 | Comparator Stand – Granite – Luthra Make – Asymmetrical Mounted – Without Dial

Size	150 x 100 x 50	250 x 150 x 50	300 x 200 x 50
Code	LGS-2A	LGS-3A	LGS-4A
Rs.	3700	4350	4900
Catalog	Page No – 4,5	Page No – 4,5	Page No – 4,5

75 – 3 | Comparator Stand – Cast Iron – Luthra Make - Centrally Mounted – Without Dial

Size	60 Dia	125 x 100	225 x 150	200 x 200	300 x 300
Code	LCS-1C	LCS-2C	LCS-3C	LCS-4C	LCS-5C
Fine Adj. Rs.	2650	3100	4100	5100	6450
Without find Adj. Rs.	1650	2100	3000	3900	5100
Catalog	Page No – 4,5	Page No – 4,5	Page No – 4,5	Page No – 4,5	Page No – 4,5

75 – 4 | Comparator Stand – Cast Iron – Luthra Make - Asymmetrical Mounted – Without Dial

Size	125 x 100	225 x 150	200 x 200	300 x 300
Code	LCS-2A	LCS-3A	LCS-4A	LCS-5A
Rs.	2350	3400	4350	5550
Catalog	Page No – 4,5	Page No – 4,5	Page No – 4,5	Page No – 4,5

75 – 5 | Comparator Stand – Granite – Unity Make

Sr. No	Range in mm	Table Size	Plain base	Serrated base	Transfer Stand (W/o Dial)	Catalog
CS-3A	200	100x150	Rs. 6000	Rs. 6200	Rs. 6200	Page – 6,7,8
CS-3B	300	100x150	Rs. 7200	Rs. 7700		Page – 6,7,8

*** 15% vat for Granite Stand or 2 % against C form.

*** 5 % vat for Cast Iron stand or 2 % against C form.

Terms & Conditions –

- Goods offered - Subject to Prior Sale
- Price Validity: "15 Days from Date of Quotation"
- C.S.T 2% extra against form C. Otherwise 5% without form C For Out of Gujarat Sales only.
- VAT 5% extra for Sales within Gujarat. Prices Ex-Godown Ahmedabad.
- Payment against Proforma Invoice, Packing, Forwarding & Freight extra.
- **Bank Detail** – Kotak Mahindra Bank Ltd.
- **Branch** – Shivranjini
- **Bank IFSC Code** - KKBK 0000 810
- **Bank Account No.** 08102 00000 2689
- Note - While making payment online do mention your Company's name.
- TIN NO 24070901229 , CST No. 24570901229
- We are looking forward to your valued orders.

GRAPH DATUM MAKE

GCS-1



- Size : 250 X 150 mm
- Working Height : **200 mm**
- Throat Depth : 90 mm
- Pillar Diameter : 30 mm (Threaded)
- Fine Adjustment : By Spring Loaded Screw
- Fine Adj. Range : 1 mm

GCS-2



- Size : 250 x 150 mm
- Working Height : **300 mm**
- Throat Depth : 90 mm
- Pillar Diameter : 30 mm (Threaded)
- Fine Adjustment : By Spring Loaded Screw
- Fine Adj. Range : 1 mm

GCS-3



- Size : 250 x 150 mm
- Working Height : **200 mm**
- Throat Depth : 120 mm
- Pillar Diameter : 20 mm (Plain)

GCS-4

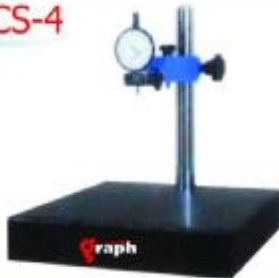

- Size : 300 x 300 mm
- Working Height : **200 mm**
- Throat Depth : 90 mm
- Pillar Diameter : 30 mm (Threaded)
- Fine Adjustment : By Spring Loaded Screw
- Fine Adj. Range : 1 mm

GCS-5



- Size : 300 x 300 mm
- Working Height : **300 mm**
- Throat Depth : 90 mm
- Pillar Diameter : 30 mm (Threaded)
- Fine Adjustment : By Spring Loaded Screw
- Fine Adj. Range : 1 mm

GCS-6



- Size : 300 x 200 mm
- Working Height : **200 mm**
- Throat Depth : 230 mm
- Pillar Diameter : 30 mm (Threaded)

GCS-7



- Size : 300 x 300 mm
- Working Height : **200 mm**
- Throat Depth : 230 mm
- Pillar Diameter : 30 mm (Threaded)

GCS-8



- Size : 300 x 300 mm
- Working Height : **300 mm**
- Throat Depth : 230 mm
- Pillar Diameter : 30 mm (Threaded)

GCS-9



- Size : 150 x 150 mm
- Working Height : **200 mm**
- Throat Depth : 120 mm
- Pillar Diameter : 20 mm (Plain)



- Measuring Base : Selected Black Granite Base Comparator Stand.
- Clamping Stem Diameter : 8mm
- Note : All the Comparator Stand are without Dial Gauge.
- Other Size available on request.

Manufacture Of : Granite Surface Plates & Comparator Stand

LUTHRA MAKE

Cast Iron Comparator Stand



Granite Comparator Stand



COMPARATOR STANDS-GRANITE

CENTRALLY MOUNTED
(WITHOUT DIAL)



MODEL NO.	BASE SIZE (MM)	HEIGHT (MM)	PILLAR CENTRALLY MOUNTED (c)	
			Without Fine Adjustment	With Fine Adjustment
LGS-1c	150 x 100 x 50	100	2000	3150
LGS-2c	250 x 150 x 50	150	3250	4500
LGS-3c	300 x 200 x 50	200	3900	5200
LGS-4c	300 x 300 x 50	250	4450	5800

COMPARATOR STANDS-GRANITE

ASYMMETRICAL MOUNTED
(WITHOUT DIAL)



MODEL NO.	BASE SIZE (MM)	HEIGHT (MM)	PILLAR ASYMMETRICAL MOUNTED (a)
LGS-2a	250 x 150 x 50	150	3700
LGS-3a	300 x 200 x 50	200	4350
LGS-4a	300 x 300 x 50	250	4900

COMPARATOR STANDS C.I.

CENTRALLY MOUNTED
(WITHOUT DIAL)



MODEL NO.	BASE SIZE (MM)	HEIGHT (MM)	PILLAR CENTRALLY MOUNTED (c)	
			Without Fine Adjustment	With Fine Adjustment
LCS-1c	60 Dia	100	1650	2650
LCS-2c	125 x 100	150	2100	3100
LCS-3c	225 x 150	200	3000	4100
LCS-4c	200 x 200	200	3900	5100
LCS-5c	300 x 300	250	5100	6450

COMPARATOR STANDS C.I.

ASYMMETRICAL MOUNTED
(WITHOUT DIAL)



MODEL NO.	BASE SIZE (MM)	HEIGHT (MM)	PILLAR ASYMMETRICAL MOUNTED (a)
LCS-2a	125 x 100	150	2350
LCS-3a	225 x 150	200	3400
LCS-4a	200 x 200	200	4350
LCS-5a	300 x 300	250	5550

Other Sizes on Request

UNITY MAKE

COMPARATOR STANDS

Unity offers 8 various models of comparator stands with steel (plain/serrated) or granite bases. These stands are suitable for precision & exact comparative measurements of height & diameter and are widely used in standard rooms; R & D laboratories & production shops.

COMPARATOR STAND Model CS 1

(0908001)

It is a small, sturdy and compact comparator stand with cast iron base provided with hardened, ground and finely lapped 58 mm dia round plain/serrated base. Has a vertical column hardened & ground fitted with bracket for dial gauge. The bracket for the dial gauge is having dovetail arrangement for fine adjustment of the dial for zero-setting.

SPECIFICATIONS

Base Surface (mm)	58 dia.
Max. Gauging Height (mm)	100
Throat Depth (mm)	67
Fine Adjustment (mm)	2mm thro. dovetail arrangement
Dial Stem Clamping Diameter (mm)	8H7
Weight (kg.)	4.5

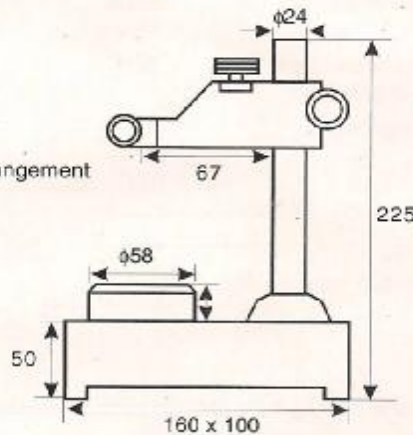
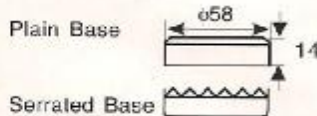

Please specify type of base (plain/ serrated) while ordering

COMPARATOR STAND Model CS 2

(0908002)

It is a medium, sturdy and rugged comparator stand. It is provided with hardened, ground and lapped rectangular flat / serrated base. It is fitted with upright column with mounting bracket for dial gauge. This bracket is having special spring sheet assembly for fine adjustment of the dial gauge for zero-setting.

SPECIFICATIONS

Base Surface (mm)	95 x 90
Max. Gauging Height (mm)	150
Throat Depth (mm)	77
Fine Adjustment (mm)	2mm thro' spring sheet assembly
Dial Stem Clamping Diameter (mm)	8H7
Weight (kg)	5.5

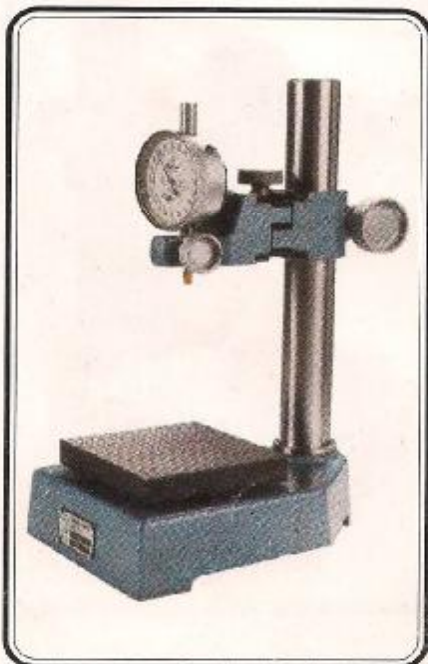
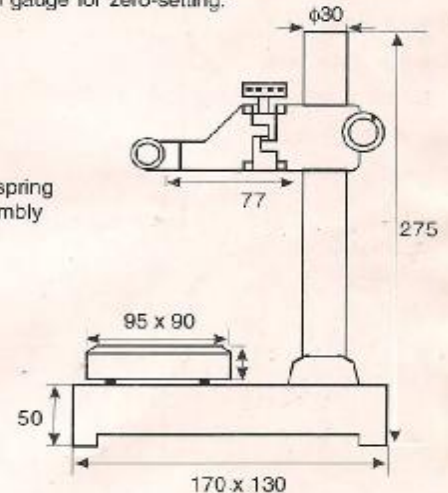
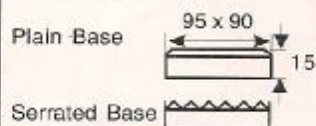

Please specify type of base (plain /serrated) while ordering

COMPARATOR STAND Model CS 3 (A & B)

Sturdy and rugged comparator stands with cast-iron base. They are provided with hardened stress relieved ground and lapped rectangular flat / serrated base. The hardened & ground vertical column is fitted to the base at the corner of the table. This allows the dial gauge to be positioned vertically over all the points on the base. The vertical column is available in two lengths 300mm and 400mm for CS 3A & CS 3B models respectively. The column has a helical threaded arm on which the dial gauge is fixed and can be accurately positioned on the job by means of a threaded nut. The sliding arm allows the indicating device to be brought into any position above the plain table. This enables checking of workpieces of large dimensions.

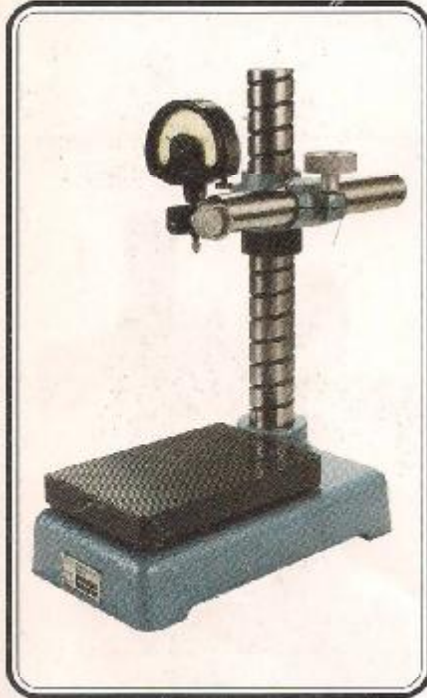

SPECIFICATIONS	CS 3A (0908003)	CS 3B (0908004)
Base Surface (mm)	150 x 100	150 x 100
Max. Gauging Height (mm)	200	300
Max. Throat Depth (mm)	140	140
Fine Adjustment (mm)	entire stroke	entire stroke
Dial Stem Clamping Diameter (mm)	8H7	8H7
Weight (kg)	8.5	9.5

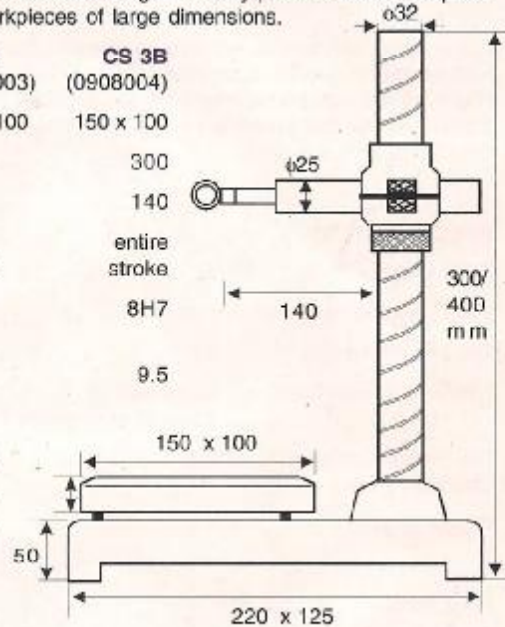
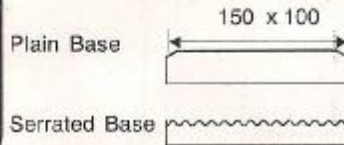

Please specify type of base (plain /serrated) while ordering

COMPARATOR STAND Model CS 4 (0908005)

Heavy duty, versatile & rugged comparator stand with cast-iron base. It is provided with reversible type hardened & ground anvil (table). One side with longitudinal grooves & other side is flat. Both sides are precision lapped. It is fitted with hardened & ground threaded column nut for vertical height setting. The dial gauge mounting bracket is provided with special spring sheet assembly for fine adjustment of the dial gauge for zero-setting.

SPECIFICATIONS

Base Surface (mm)	90 x 35
Max. Gauging height (mm)	125
Throat Depth (mm)	65
Fine Adjustment (mm)	2mm thro' special spring sheet assembly.
Dial Stem Clamping Diameter (mm)	8H7
Weight (kg)	11.5

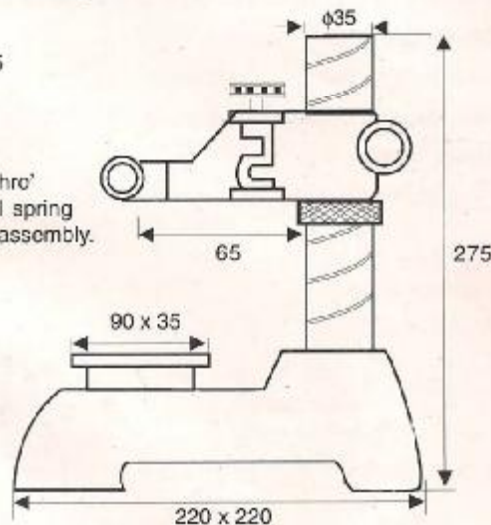
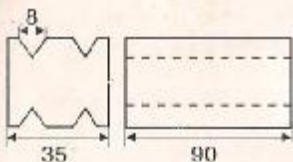

COMPARTOR STAND Model CS 5 (0908006)

Sturdy rugged comparator stand. The rectangular anvil made out of high grade steel is stress relieved, hardened, ground and finely lapped. fitted to the Cast-iron base. The upright column is provided with rack and pinion mechanism for vertical movement of the dial gauge.

SPECIFICATIONS

Base Surface (mm)	95 x 90
Max. Gauging Height (mm)	150
Throat Depth (mm)	77
Fine Adjustment (mm)	Entire stroke by rack & pinion
Dial Stem Clamping Diameter (mm)	8H7
Weight (kg)	5.5

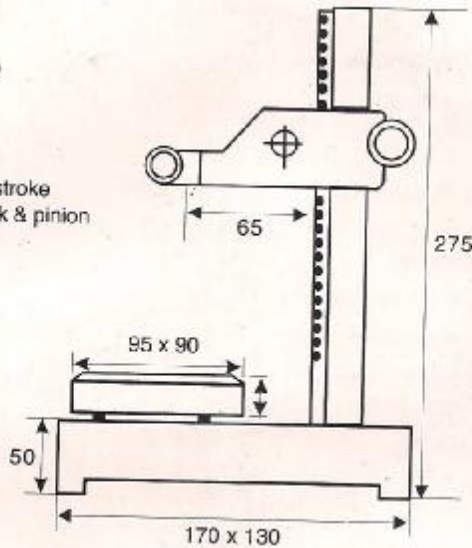
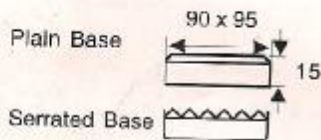

Please specify type of base (plain / serrated) while ordering

TRANSFER STAND MODEL TS (0908012)

It is fitted to the cast-iron base. It is available with both plunger type & lever type dial bracket and can be used as comparator stand as well as transfer stand for transfer of readings. It is useful and important accessory for height micrometer.

SPECIFICATIONS

Base surface (Serrated)	58 dia.
Max. Gauging Height (mm)	350
Throat Depth (mm)	60
Fine Adjustment (mm)	2
Dial Stem/Lever type Dial Attachment	8H7
Clamping Diameter (mm)	
Weight (kg.)	5.0

