



# BEARING & TOOL CENTRE



## Head Office

1<sup>st</sup> Floor, Vyapar Bhavan, Kadia Kui,  
Relief Road, Ahmedabad - 380001.  
Ph:- 079 - 22160386, 65254835, 22134835  
Mobile : 7819819941, 9375706649

## Ahmedabad Branch

GF-B-14, Jayraj Complex, Nr. Soni ni Chawl,  
Odhav, Ahmedabad - 382415.  
Ph:- 079 - 22890202, 65458950, 65404657, 65400202  
Mobile : 7878825197, 7819819938, 9375706648

Website : [www.bearingtoolcentre.com](http://www.bearingtoolcentre.com), [www.bearingtoolscentre.com](http://www.bearingtoolscentre.com) | Email : [info@bearingtoolcentre.com](mailto:info@bearingtoolcentre.com)

## Our Sister Concern : RELIEF SERVICE CENTRE

Repairs, Removal of Jaw Error, Bore Gauge Extension, Instrument Modifications & Spares

## Quotation

20 | Digit / Counter Outside Micrometer | Least Count 0 . 01 mm

Range-mm ( Outside )	W	C	D %	0-25	25-50	50-75	75-100
Type				A	B		
InsizeRs.	6	N		3581	2895	3247	3568
Code				3400-25	3400-50	3400-75	3400-100
Catalog				Page No-2	Page No-2	Page No-2	Page No-2
Aerospace Rs.		N	10	1100	1300		
MitutoyoRs.	12	N	5	5020	6484	7970	8430
Code				193-101	193-102	193-103	193-104
Catalog				Page No-3	Page No-3	Page No-3	Page No-3
MitutoyoRs	12	N	5	5146	6574	7970	8673
Code **0.001mm				193-111	193-112	193-113	193-114
Catalog				Page No-3	Page No-3	Page No-3	Page No-3

Note:- Aerospace item once sold will not be taken back even if it is Faulty.

\*\*0.001mm reading is obtained with vernier.

\*\*\* Warranty, Certificate, Discount

## Terms & Conditions –

- Goods offered - Subject to Prior Sale
- Price Validity: "15 Days from Date of Quotation"
- C.S.T 2% extra against form C. Otherwise 5% without form C For Out of Gujarat Sales only.
- VAT 5% extra for Sales within Gujarat. Prices Ex-Godown Ahmedabad.
- Payment against Proforma Invoice, Packing, Forwarding & Freight extra.
- **Bank Detail** – Kotak Mahindra Bank Ltd.
- **Branch** – Shivranjini
- **Bank IFSC Code** - KKBK 0000 810
- **Bank Account No.** 08102 00000 2689
- Note - While making payment online do mention your Company's name.
- TIN NO 24070901229 , CST No. 24570901229
- We are looking forward to your valued orders.

# INSIZE MAKE

## OUTSIDE MICROMETER WITH COUNTER



3400-25

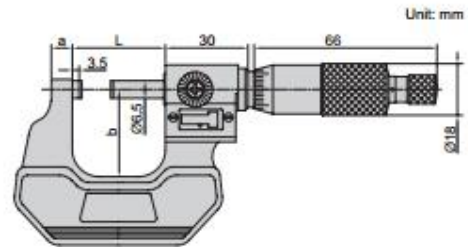

Code	Range	Accuracy	L	a	b
3400-25*	0-25mm	4µm	32	6	26
3400-50*	25-50mm	4µm	57	8	32
3400-75*	50-75mm	5µm	82	8	44.5
3400-100*	75-100mm	5µm	107	8	57

(mm)

- Counter resolution: 0.01mm
- Thimble graduation: 0.01mm
- Carbide measuring faces
- Meet DIN 863
- Ratchet stop
- Supplied with setting standards (except 0-25mm)

\* Supplied with manufacturer inspection certificate traceable to DKD Germany

# MITUTOYO MAKE

## Digit Outside Micrometers

### SERIES 193

#### FEATURES

- Mechanical digit counter with 0.01 mm or .001" reading for quick and error-free reading.

- With a standard except for 25mm model.



193-101

#### Technical Data

Accuracy: Refer to the list of specifications.  
 Counter reading: 0.01mm or .001"  
 Graduation: 0.01mm, 0.001mm, .001" or .0001"  
 Flatness: 0.6µm  
 Parallelism: (2+R/100)µm, R = max. range (mm)  
 +fraction rounded down  
 Measuring faces: Carbide tipped



193-916

#### SPECIFICATIONS

Metric			With ratchet stop		
Range	Order No.	Accuracy	Range	Order No.	Accuracy
0 - 25mm	193-101	±2µm	25 - 50mm	193-102	±2µm
	193-111*	±2µm		193-112*	±2µm
50 - 75mm	193-103	±2µm	75 - 100mm	193-104	±3µm
	193-113*	±2µm		193-114*	±3µm
100 - 125mm	193-305	±3µm	125 - 150mm	193-306	±3µm
150 - 175mm	193-307	±4µm	175 - 200mm	193-308	±4µm
200 - 225mm	193-309	±4µm	225 - 250mm	193-310	±5µm

\*0.001mm reading is obtained with vernier.

Inch			With ratchet stop		
Range	Order No.	Accuracy	Range	Order No.	Accuracy
2" - 3"	193-213*	±.0001"	3" - 4"	193-214*	±.00015"
4" - 5"	193-415*	±.00015"	5" - 6"	193-416*	±.00015"
6" - 7"	193-417*	±.0002"	7" - 8"	193-418*	±.0002"
8" - 9"	193-419*	±.0002"	9" - 10"	193-420*	±.00025"
10" - 11"	193-421*	±.00025"			

\*.0001" reading is obtained with vernier.

Inch			With friction thimble		
Range	Order No.	Accuracy	Range	Order No.	Accuracy
0 - 1"	193-201	±.0001"	1" - 2"	193-211*	±.0001"
	193-211*	±.0001"		193-212*	±.0001"

\*.0001" reading is obtained with vernier.

Metric			Micrometer set		
Range	Order No.	Assortment of micrometers	Range	Order No.	Assortment of micrometers
0 - 75mm (3 pcs./set)	193-901	• 193-101, 193-102, 193-103 • 2 micrometer standards	0 - 3" (3 pcs./set)	193-923	• 193-211, 193-212, 193-213 • 2 micrometer standards
0 - 100mm (4 pcs./set)	193-902	• 193-101, 193-102, 193-103, 193-104 • 3 micrometer standards	0 - 6" (6 pcs./set)	193-930	• 193-211, 193-212, 193-213, 193-214, 193-415, 193-416 • 5 micrometer standards
0 - 150mm (6 pcs./set)	193-908	• 193-101, 193-102, 193-103, 193-104, 193-305, 193-306 • 5 micrometer standards			

Inch			Micrometer set		
Range	Order No.	Assortment of micrometers	Range	Order No.	Assortment of micrometers
0 - 3" (3 pcs./set)	193-923	• 193-211, 193-212, 193-213 • 2 micrometer standards	0 - 6" (6 pcs./set)	193-930	• 193-211, 193-212, 193-213, 193-214, 193-415, 193-416 • 5 micrometer standards

## DIMENSION

### Models up to 100mm

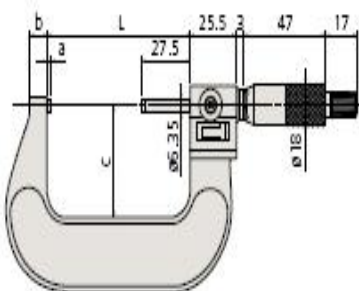

### Models over 100mm

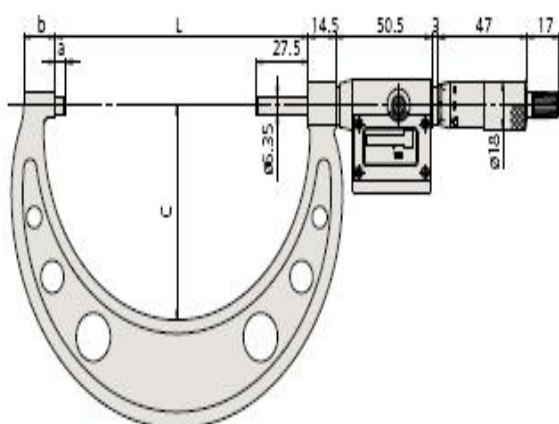

Unit: mm

Range	L	a	b	c
0 - 25mm	30	2.5	5	26
25 - 50mm	55	2	8	32
50 - 75mm	80	2	9	45
75 - 100mm	105	2	9	57
100 - 125mm	132.8	5.3	17	79
125 - 150mm	158.2	5.7	19	94
150 - 175mm	183.6	6.1	19	106
175 - 200mm	208.8	6.3	18	118
200 - 225mm	234.2	6.7	17	130
225 - 250mm	258.0	5.5	18	143

Note: The shape of the thimble changes on the model with Friction Thimble.