



# BEARING & TOOL CENTRE



## Head Office

1<sup>st</sup> Floor, Vyapar Bhavan, Kadia Kui,  
Relief Road, Ahmedabad - 380001.  
Ph:- 079 - 22160386, 65254835, 22134835  
Mobile : 7819819941, 9375706649

## Ahmedabad Branch

GF-B-14, Jayraj Complex, Nr. Soni ni Chawl,  
Odhav, Ahmedabad - 382415.  
Ph:- 079 - 22890202, 65458950, 65404657, 65400202  
Mobile : 7878825197, 7819819938, 9375706648

Website : [www.bearingtoolcentre.com](http://www.bearingtoolcentre.com), [www.bearingtoolscentre.com](http://www.bearingtoolscentre.com) | Email : [info@bearingtoolcentre.com](mailto:info@bearingtoolcentre.com)

## Our Sister Concern : RELIEF SERVICE CENTRE

Repairs, Removal of Jaw Error, Bore Gauge Extension, Instrument Modifications & Spares

### Quotation

#### 28 | Dial Vernier Caliper [Least Count – 0.02 mm ]

Range-mm	W	C	D %	0 - 100	0-150	0-200	0-300	0 – 450	0 – 600
Insize Rs.	12	Y			2407	3206	5627		
Code					<b>1312-150A</b>	<b>1312-200A</b>	<b>1312-300A</b>		
Catalog					Page No. - 2	Page No. - 2	Page No. - 2		
Aerospace Rs.		N	10		850	1270	1720	7130	9380
Advance Rs.		N	10		1400	2000	3200		
M & W Rs.	6	N		1200	2100	2800	4100	7500	8500
Code (DC)					<b>150</b>	<b>200</b>	<b>300</b>	<b>450</b>	<b>600</b>
M & W Titanium Rs.	6	N			2500	3500	4800		
Catalog					Page No. - 2	Page No. - 2	Page No. - 2		
Baker Rs.	12	Y	15		2610	4370	5820		
Code					<b>DC 10</b>	<b>DC 20</b>	<b>DC30</b>		
Catalog					Page No. - 4,5	Page No. - 4,5	Page No. - 4,5		
Precision – Std. Rs.	12	Y	20		2200	3000	4800		
Precision – Premium Rs.	12	Y	20		2700	3400			
Mitutoyo Rs.	12	Y	5		4393	6137	8911		
Code					<b>505-730/683</b>	<b>505-731</b>	<b>505-745</b>		
Catalog					Page No. - 5	Page No. - 5	Page No. - 5		
Mitutoyo Rs. – inch	12		5		6325	8015			
Code		Y			<b>505-675</b>	<b>505-676 / 743</b>			
Catalog					Page No. - 5	Page No. - 5			

#### 29 | Dial Vernier Caliper [Least Count – 0.01 mm ]

Range-mm	W	C	0-100	150	200	300
Insize Rs.	12	Y		3208	4412	6898
Code				<b>1311-150</b>	<b>1311-200</b>	<b>1311-300</b>
Catalog				Page No. - 2	Page No. - 2	Page No. - 2
M & W Rs.	6	N	1400	2400	3000	4000
Code				<b>DCF 150</b>	<b>DCF 200</b>	<b>DCF 300</b>
Catalog				Page No. - 3	Page No. - 3	Page No. - 3
Yamayo- Cla Rs.		N		2000	2850	
Mitutoyo Rs.	12	Y	5	4832	6626	
Code				<b>505-732</b>	<b>505-733</b>	
Catalog				Page No. - 5	Page No. - 5	

Note:- Aerospace item once sold will not be taken back even if it is Faulty.

\*\*\* W – Warranty, C – Certificate, D- Discount

## Terms & Conditions –

- Goods offered - Subject to Prior Sale
- Price Validity: "15 Days from Date of Quotation"
- C.S.T 2% extra against form C. Otherwise 5% without form C For Out of Gujarat Sales only.
- VAT 5% extra for Sales within Gujarat. Prices Ex-Godown Ahmedabad.
- Payment against Proforma Invoice, Packing, Forwarding & Freight extra.
- **Bank Detail** – Kotak Mahindra Bank Ltd.
- **Branch** – Shivranjini
- **Bank IFSC Code** - KKBK 0000 810
- **Bank Account No.** 08102 00000 2689
- Note - While making payment online do mention your Company's name.
- TIN NO 24070901229 , CST No. 24570901229
- We are looking forward to your valued orders.

# INSIZE MAKE



- Shockproof dial indicator
- Made of stainless steel

Dial indicator graduation: 0.02mm (mm)

Code	Range	Accuracy	L	a	b	c	d	D
1312-150A*	0-150mm	±0.03mm	235	21	16.5	16	40	Ø39
1312-200A*	0-200mm	±0.03mm	288	24	19	16	48	Ø39
1312-300A*	0-300mm	±0.04mm	410	28	22	20	62	Ø44.5

Dial indicator graduation: 0.01mm (mm)

Code	Range	Accuracy	L	a	b	c	d	D
1311-150A*	0-150mm	±0.03mm	235	21	16.5	16	40	Ø39
1311-200A*	0-200mm	±0.03mm	288	24	19	16	48	Ø39
1311-300A*	0-300mm	±0.04mm	410	28	22	20	62	Ø44.5

\* Supplied with manufacturer inspection certificate traceable to DKD Germany

## DIAL CALIPER



1312-150A

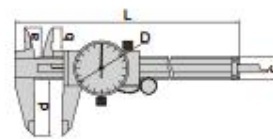

# M&W MAKE



## Features :

- Made of hardened stainless steel
- Shock proof
- 4-way measurement
- Yellow indicator plates with clear black points
- Premium TIN coated model[DCJ}



Range	Reading
0-150MM	0.02mm/0.01mm
0-200mm	0.02mm/0.01mm
0-300mm	0.02mm/0.01mm
0-450mm	0.02mm/0.01mm
0-600mm	0.02mm/0.01mm

# BAKER MAKE



## CALIPERS

### DIAL CALIPERS

PRODUCT CODE	DESCRIPTION	UNIT RATE ₹
D85049000	BAKER Dial Caliper <b>Type DC10</b> with adjustable Bezel. Reading : 0.02 mm Range : 0 - 150 mm	2,610.00
D85059000	BAKER Dial Caliper <b>Type DC20</b> with adjustable Bezel. Reading : 0.02 mm Range : 0 - 200 mm	4,370.00
D85069000	BAKER Dial Caliper <b>Type DC30</b> with adjustable Bezel. Reading : 0.02 mm Range : 0 - 300 mm	5,820.00

## DIAL CALIPERS





### TYPE DC10

TYPE	READING	MEASURING RANGE
DC10	0.02 mm	0-150 mm
DC20	0.02 mm	0-200 mm
DC30	0.02 mm	0-300 mm

ACCURACY : AS PER DIN 862

### Calibration Certificate – Baker Make

BAKER <i>a passion for precision</i>		BAKER GAUGES INDIA PRIVATE LIMITED (BMI DIV.)		QA/80/00
		CERTIFICATE OF CALIBRATION - DIAL CALIPER		000507
TYPE <b>DC-20</b>	MEASUREMENT	SPECIFIED (mm)	ACTUAL (mm)	Accuracy : As per DIN 862 Max. error : 0.02 mm upto 100 mm 0.03 mm above 100 mm Uncertainty of measurement $\pm 0.014$ mm at 95% confidence level with coverage factor k=2
RANGE <b>0-200 mm</b>	EXTERNAL	50.00	50.00	
		100.00	100.00	
		200.00	200.00	
READING <b>0.02 mm</b>	INTERNAL	20.00	19.98	
	DEPTH	20.00	20.00	
	STEP	20.00	20.02	
SERIAL NO :- <b>C1012010156</b>	TRACEABILITY	International Length Standards vide certificate No P/09/90044 Valid upto Oct.2011.		 QA 

AN ISO 9001- 2008 Company

# MITUTOYO MAKE

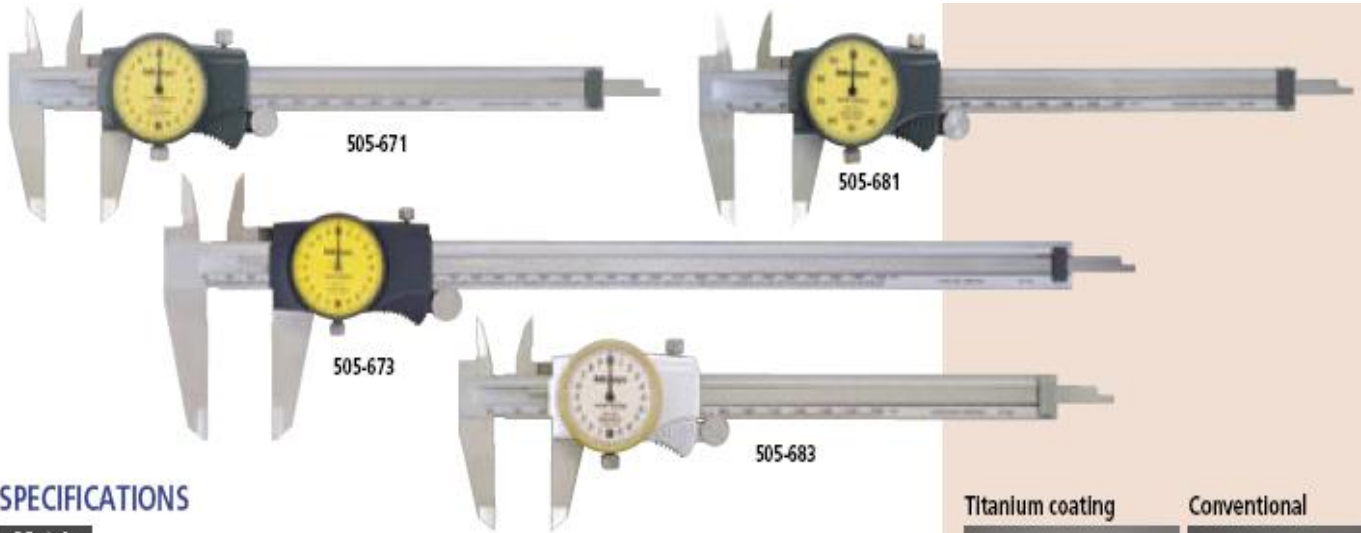

## SPECIFICATIONS

Metric				
Range	Order No.	Accuracy	Remarks (dial reading / others)	
0 - 100mm	505-680	±0.015mm	0.01mm, 1mm/rev	—
0 - 150mm	505-671 / 505-683*	±0.03mm	0.02mm, 2mm/rev	—
0 - 150mm	505-707	±0.03mm	0.02mm, 2mm/rev	Carbide-tipped jaws for OD measurement
0 - 150mm	505-711	±0.03mm	0.02mm, 2mm/rev	Carbide-tipped jaws for OD & ID measurement
0 - 150mm	505-681 / 505-685*	±0.02mm	0.01mm, 1mm/rev	—
0 - 200mm	505-672 / 505-684*	±0.03mm	0.02mm, 2mm/rev	—
0 - 200mm	505-682 / 505-686*	±0.03mm	0.01mm, 1mm/rev	—
0 - 300mm	505-673	±0.04mm	0.02mm, 2mm/rev	—

\*Silver cover type

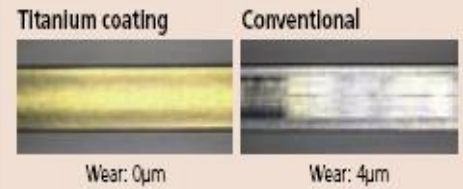

## Technical Data

Accuracy: Refer to the list of specifications.  
Dial reading: Refer to the list of specifications.

Range	Order No.	Accuracy	Remarks (dial reading / others)
0 - 4"	505-674	±.001"	.001", .1"/rev
0 - 6"	505-675 / 505-689*	±.001"	.001", .1"/rev
0 - 6"	505-708	±.001"	.001", .1"/rev
0 - 6"	505-712	±.001"	.001", .1"/rev
0 - 8"	505-676 / 505-690*	±.002"	.001", .1"/rev
0 - 8"	505-709	±.002"	.001", .1"/rev
0 - 8"	505-713	±.002"	.001", .1"/rev
0 - 12"	505-720	±.002"	.001", .2"/rev
0 - 12"	505-677*	±.002"	.001", .1"/rev
0 - 12"	505-721	±.002"	.001", .2"/rev
0 - 12"	505-710*	±.002"	.001", .1"/rev
0 - 12"	505-714*	±.002"	.001", .1"/rev

\*Silver cover type

## DIMENSION

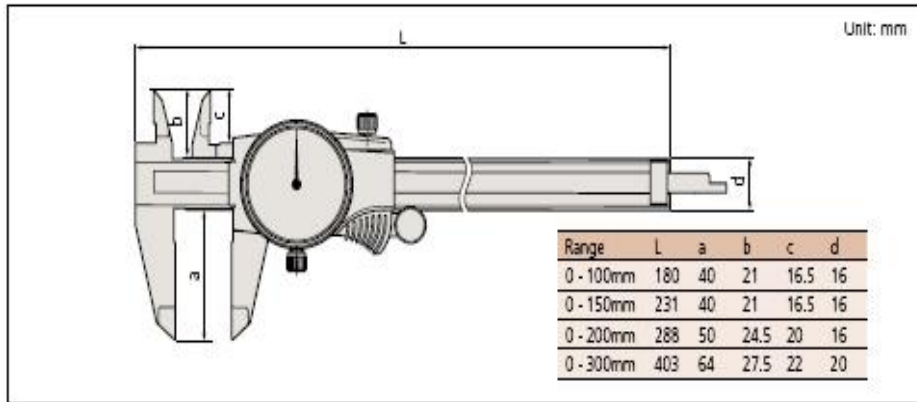

# How To Use

