



BEARING & TOOL CENTRE



Head Office

1st Floor, Vyapar Bhavan, Kadia Kui,
Relief Road, Ahmedabad - 380001.
Ph:- 079 - 22160386, 65254835, 22134835
Mobile : 7819819941, 9375706649

Ahmedabad Branch

GF-B-14, Jayraj Complex, Nr. Soni ni Chawl,
Odhav, Ahmedabad - 382415.
Ph:- 079 - 22890202, 65458950, 65404657, 65400202
Mobile : 7878825197, 7819819938, 9375706648

Website : www.bearingtoolcentre.com, www.bearingtoolscentre.com | Email : info@bearingtoolcentre.com

Our Sister Concern : RELIEF SERVICE CENTRE

Repairs, Removal of Jaw Error, Bore Gauge Extension, Instrument Modifications & Spares

Quotation

34 | Gear Tooth Vernier

Range	W	C	1 - 26
Aerospace Rs.		N	2630
M & WRs.	6	N	3800
Code			GTV
Catalog			Page No. - 2

34 - 1 | Digital Gear Tooth Vernier

Range	W	C	D%	1 - 30	5 - 50
InsizeRs.	12	Y		18769	21646
Code				1181-M25A	1181-M50A
Catalog				Page No. - 2	Page No. - 2
Aerospace Rs.	-	N		11250	12500

NABL Calibration For any New Instrument Purchase from us @ Rs. 200/-. Except for Item In set (E.g. Feeler / Slip Gauge Etc.)

Note:- Aerospace item once sold will not be taken back even if it is Faulty.

*** W – Warranty , C – Certificate , D- Discount

Terms & Conditions –

- Goods offered - Subject to Prior Sale
- Price Validity: "15 Days from Date of Quotation"
- C.S.T 2% extra against form C. Otherwise 5% without form C For Out of Gujarat Sales only.
- VAT 5% extra for Sales within Gujarat. Prices Ex-Godown Ahmedabad.
- Payment against Proforma Invoice, Packing, Forwarding & Freight extra.
- **Bank Detail** – Kotak Mahindra Bank Ltd.
- **Branch** – Shivranjini
- **Bank IFSC Code** - KKBK 0000 810
- **Bank Account No.** 08102 00000 2689
- Note - While making payment online do mention your Company's name.
- TIN NO 24070901229 , CST No. 24570901229
- We are looking forward to your valued orders.

INSIZE MAKE

DATA
OUTPUT

DIGITAL GEAR TOOTH CALIPER

- Resolution: 0.01mm/0.0005"
- Carbide tips
- Buttons: zero, on/off, mm/inch
- Battery LR44
- Data output
- Made of stainless steel
- Optional accessory: data output cable (code 7306-20, 7302-SPC1A/SPC1B, 7305-SPC2A)

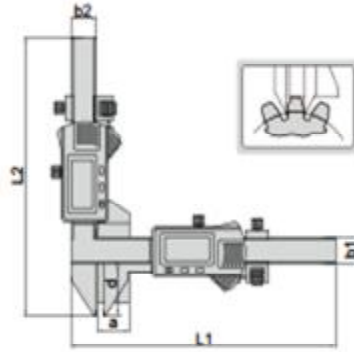

1181-M25A

Code	Range	Accuracy	L1	L2	a	b1	b2	d
1181-M25A	M1-25mm	±0.04mm	170	165.5	21	16	16	30.5
1181-M50A	M5-50mm	±0.04mm	220	190	50.5	16	16	55

M&W MAKE

Features :

Special vernier caliper for measuring gear module
fine adjustment in both axes



Range	Reading
Module 1-26mm	0.02mm