



# BEARING & TOOL CENTRE



## Head Office

1<sup>st</sup> Floor, Vyapar Bhavan, Kadia Kui,  
Relief Road, Ahmedabad - 380001.  
Ph:- 079 - 22160386, 65254835, 22134835  
Mobile : 7819819941, 9375706649

## Ahmedabad Branch

GF-B-14, Jayraj Complex, Nr. Soni ni Chawl,  
Odhav, Ahmedabad - 382415.  
Ph:- 079 - 22890202, 65458950, 65404657, 65400202  
Mobile : 7878825197, 7819819938, 9375706648

Website : [www.bearingtoolcentre.com](http://www.bearingtoolcentre.com), [www.bearingtoolscentre.com](http://www.bearingtoolscentre.com) | Email : [info@bearingtoolcentre.com](mailto:info@bearingtoolcentre.com)

## Our Sister Concern : RELIEF SERVICE CENTRE

Repairs, Removal of Jaw Error, Bore Gauge Extension, Instrument Modifications & Spares

### Quotation

#### 55 | Magnetic Stand / Dial Gauge Stand

| TYPE          | W  | C | D% | Standard       | Std – with fine | Universal           | Flexible        | Heavy Duty     | Mic. stand   |
|---------------|----|---|----|----------------|-----------------|---------------------|-----------------|----------------|--------------|
| Insize Rs.    | 12 | N |    | 1128           | 1045            | 2733                | 2285            |                | 766          |
| Code          |    |   |    | <b>6200-60</b> | <b>6201-60</b>  | <b>6208-80A</b>     | <b>6207-80A</b> |                | <b>6301</b>  |
| Catalog       |    |   |    | Page No. - 3   | Page No. - 3    | Page No. - 3        | Page No. - 3    |                | Page No. - 3 |
| Aerospace Rs. |    | N | 10 | 530            | 550             | 1200                | 1400            |                | 840          |
| M & W Rs.     | 6  | N |    | 900            | 900             |                     | 1700            |                | 750          |
| Groz Rs.      |    |   | 22 |                | 2080            | 2970                |                 |                |              |
| Code          |    |   |    |                | <b>MB31/F</b>   | <b>MB32/F</b>       |                 |                |              |
| Jafuji Rs.    |    | Y | 18 | 1450           | 1600            | 2800                |                 | 2100           |              |
| Code          |    |   |    | <b>JMB 102</b> | <b>JMB 103</b>  | <b>JMB 106</b>      |                 | <b>JMB 101</b> |              |
| Catalog       |    |   |    | Page No. - 6,7 | Page No. - 7,8  | Page No. - 8,9      |                 | Page No. - 6   |              |
| Mitutoyo Rs.  | 12 | N | 5  | 1519           | 1694            | 12266               | 3376            |                |              |
| Code          |    |   |    | <b>7010</b>    | <b>7011</b>     | <b>7019 / 7033B</b> | <b>7012</b>     |                |              |
| Catalog       |    |   |    | Page No. - 6   | Page No. - 6    | Page No. - 6        | Page No. - 6    |                |              |

Note:- Aerospace item once sold will not be taken back even if it is Faulty.

\*\*\* W – Warranty , C – Certificate , D- Discount

#### 55 – 1 | Magnetic Stand / Dial Gauge Stand

| TYPE       | W  | C | D% | Mini             | Mini           | Uneven Surface |
|------------|----|---|----|------------------|----------------|----------------|
| Insize Rs. | 12 | N |    | 2046             | 4759           | 1731           |
| Code       |    |   |    | <b>6211-10</b>   | <b>6224-40</b> | <b>6215-60</b> |
| Catalog    |    |   |    | Page No. -4      | Page No. -4    | Page No. -4    |
| Jafuji     |    | N | 13 | 2900             |                |                |
| Code       |    |   |    | <b>JMB – 108</b> |                |                |
| Catalog    |    |   |    | Page No. -8      |                |                |

-> **Note :** Central Excise limit with effect from 1-1-2012 on Jafuji make. The rate of Duty applicable is 10.3% (10% Basic Excise Duty, 2% Edu. Cess & 1% secondary & higher Edu. Cess).

## Terms & Conditions –

- Goods offered - Subject to Prior Sale
- Price Validity: "15 Days from Date of Quotation"
- C.S.T 2% extra against form C. Otherwise 5% without form C For Out of Gujarat Sales only.
- VAT 5% extra for Sales within Gujarat. Prices Ex-Godown Ahmedabad.
- Payment against Proforma Invoice, Packing, Forwarding & Freight extra.
- **Bank Detail** – Kotak Mahindra Bank Ltd.
- **Branch** – Shivranjini
- **Bank IFSC Code** - KKBK 0000 810
- **Bank Account No.** 08102 00000 2689
- Note - While making payment online do mention your Company's name.
- TIN NO 24070901229 , CST No. 24570901229
- We are looking forward to your valued orders.

## INSIZE MAKE

**MAGNETIC STAND**

| Code     | Magnetic force | Applicable holding stem | Remark                  |
|----------|----------------|-------------------------|-------------------------|
| 6200-60  | 60kgf          | Ø8mm, Ø4mm, 3/8" DIA.   | without fine adjustment |
| 6201-60  | 60kgf          | Ø8mm, Ø4mm, 3/8" DIA.   | with fine adjustment    |
| 6202-80  | 80kgf          | Ø8mm, Ø4mm, 3/8" DIA.   | with fine adjustment    |
| 6202-100 | 100kgf         | Ø8mm, Ø4mm, 3/8" DIA.   | with fine adjustment    |

▪ For digital/dial indicators and dial test indicators

## UNIVERSAL MAGNETIC STAND

LOW LOCK FORCE



6208-80A

- For digital/dial indicators and dial test indicators

| Code     | Magnetic force | Applicable holding stem | Remark                                   |
|----------|----------------|-------------------------|--|
| 6208-80A | 80kgf          | Ø8mm                    | with fine adjustment and dovetail groove |

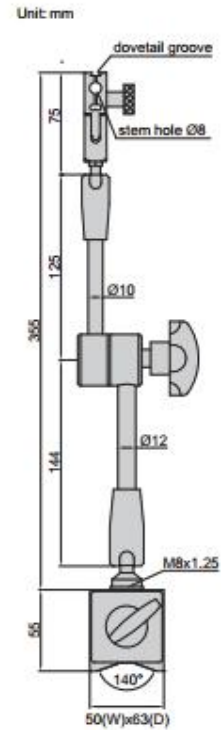

## FLEX ARM MAGNETIC STAND

ATTENTION: FOR DIAL TEST INDICATORS ONLY



6207-80A

- For dial test indicators

| Code     | Magnetic force | Applicable holding stem |
|----------|----------------|-------------------------|
| 6207-80A | 80kgf          | Ø8mm, Ø4mm, 3/8" DIA.   |

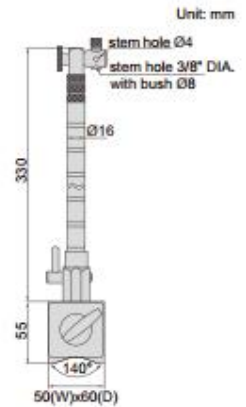

## MICROMETER STAND

- Suitable for micrometers up to 100mm

Code  
6301

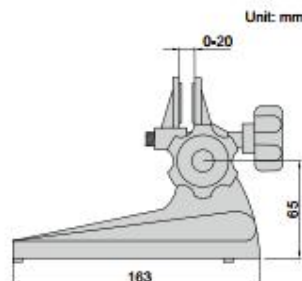

6301

## MINI MAGNETIC STAND

ATTENTION: FOR DIAL TEST INDICATORS ONLY

- For dial test indicators
- With dovetail groove

| Code    | Magnetic force | Applicable holding stem |
|---------|----------------|-------------------------|
| 6211-10 | 10kgf          | Ø6mm, Ø8mm              |



6211-10

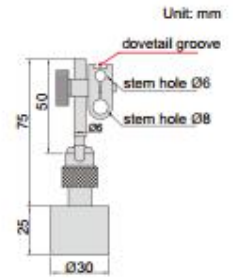

## MINI MAGNETIC STAND

ATTENTION: FOR DIAL TEST INDICATORS ONLY

- For dial test indicators
- With fine adjustment and dovetail groove

| Code    | Magnetic force | Applicable holding stem |
|---------|----------------|-------------------------|
| 6224-40 | 40kgf          | Ø8mm                    |



6224-40

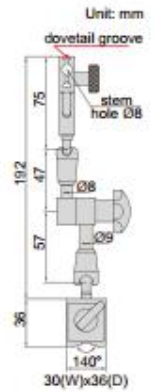

- For digital/dial indicators and dial test indicators
- With fine adjustment

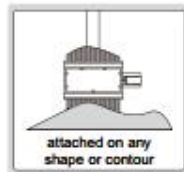

| Code    | Magnetic force | Applicable holding stem |
|---------|----------------|-------------------------|
| 6215-60 | 60kgf          | Ø8mm, Ø4mm, 3/8" DIA.   |

## MAGNETIC STAND FOR UNEVEN SURFACE

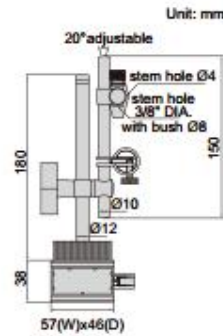

6215-60

## Flexible Dial Holding System

|  |  |  |   |  |  |
|--|--|--|---|--|--|
|  |  |  |   |  |  |
| <ul style="list-style-type: none"> <li>- Single knob operating three joints</li> <li>- Highly flexible and accurate</li> <li>- Fine adjustment assembly for precise operation</li> <li>- Various options for :                             <ul style="list-style-type: none"> <li>Base Unit</li> <li>Arm Lengths and Colour options</li> <li>Fine adjustment assembly</li> </ul> </li> </ul> |  |  | <ul style="list-style-type: none"> <li>- Innovative applications</li> <li>- Fully customisable for special requirements</li> <li>- Durable and maintenance free</li> <li>- Completely Indigenous</li> </ul> <p style="text-align: center; color: red; font-weight: bold;">** We also provide after-sales service **</p> |  |  |

The company manufactures flexible dial gauge stands which are used in any engineering industry. The stand consists of two ball joints at two ends and one swivel joint in the centre. One knob is operating all three joints. This flexibility is the beauty of the design. The construction of the stand is very rigid. It works with the wear compensation of the cam rods.

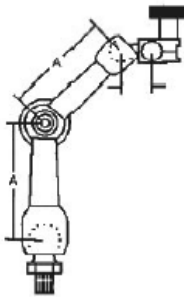

Line Diagram

| TECHNICAL SPECIFICATIONS |                 |               |                    |                             |
|--------------------------|-----------------|---------------|--------------------|-----------------------------|
| Arm Length (A)           | Fine Adjustment | Magnetic Base |                    |                             |
|                          |                 | Strength      | Size (mm)          | Type                        |
| 55mm/120mm/450mm<br>each | 4 mm<br>throw   | 40 kg<br>pull | 50 x 50<br>x 60 mm | M8 tapping on/off<br>magnet |

### DESIGN OPTIONS AND ACCESSORIES

Listing of various options that modify the Flexible Dial Holding System to suit your application. The specifications mentioned below are the standard available measurements. However, we can provide you with any specific requirement

| Fine Adjustment Assembly  | Stand Arm Length          | Dial Base Options                          | Stand Attachments        |
|---------------------------|---------------------------|--|--------------------------|
| Plastic                   | Standard [120mm each]     | Magnetic Base                              | Finger Dial Gauge        |
| Metallic with Dovetail    | Short [55mm each]         | Non-Magnetic Solid Base                    | Plunger Dial Gauge       |
| Metallic without Dovetail | Extra Long [450mm each]   | Collet Holding Stem [dia 8*40mm long stem] | Plunger Dial with holder |
|                           | Unequal arms [customized] |  | Coolant tube holder      |
|                           |                           |  | Lamp Shade               |
|                           |                           |  | Writing Pad              |
|                           |                           |  | Magnifying Glass         |
|                           |                           |  | Microphone holder        |

- 1 Flexible dial gauge stand (120mm. arm length - Metallic with dovetail) - Rs. 1050/-
- 2 Flexible dial gauge stand (120mm. arm length - Metallic without dovetail) - Rs. 1000/-
- 3 Flexible dial gauge stand (120mm. arm length - Plastic) - Rs.950/-
- 4 Magnetic base ( Chinese ) - Rs.500/-
- 5 Anubhav make heavy duty magnetic base - Rs.550/-



# MAGNETIC STANDS AND BASES

QUALITY, RELIABILITY AND VALUE FOR MONEY



**JMB-101, HEAVY DUTY**



**JMB-102, STANDARD**

## SPECIFICATIONS

**Main shaft :**

Dia : 18 mm  
Length : 235 mm.

**Height :** 295 mm

**Base size :** 50 X 60 X 60 mm

**Main shaft :**

Dai : 12 mm  
Length : 180 mm

**Height :** 240 mm

**Base size :** 50 X 60 X 60 mm

## FEATURES

- \* Heavy duty main post
- \* Two metallic blacknised knobs with universal holders
- \* Dial universal holder for stem of dia 3 mm to 11 mm

- \* Two shafts with bakelite knobs
- \* Ideal for regular production use
- \* Accepts dial gauges of stem dia 8 mm & 4 mm



# MAGNETIC STANDS AND BASES

QUALITY, RELIABILITY AND VALUE FOR MONEY

## JMB-104

### Flexible Arm

#### SPECIFICATION

Flexible shaft : 300mm  
Height : 350 mm  
Base : 50X60X60mm



## JMB-106

### SPECIFICATION

BASE : 50 X 60 X 60

### SPECIAL FEATURES

- \* The Dial Gauge can be locked in any desired position via centralised clamping.
- \* There is large radius of 260 mm
- \* The clamping hole is intended for dia 8 mm stem and there is a dovetail clamp seating for Dial Test Indicators.
- \* Fine Adjustment has been provided.

## JMB-103

### SPECIFICATION

Main Shaft :  
12mm X 180mm  
Height : 240mm  
Base : 50X60X60mm

### SPECIAL FEATURES

- \* Almost similar to JMB 102, but fine adjustment with hardened clamp and roller for quick setting.









### SPECIAL FEATURES

- \* Versatile model with flexible arm and locking lever
- \* useful for inaccessible area
- \* Universal holder for dial gauge of stem dia 4 mm to 8 mm

Milang (Arva)





|    |   |   |  |  |  |
|----|---|---|--|--|--|
| 64 |   | <p><i>Crystal</i><br/> <b>Heavy Duty<br/> Dial Indicator<br/> Stand</b><br/> (With Fine Adjustment)<br/> <b>Series AA - 111</b></p> | AA - 1110<br>AA - 1111<br>AA - 1112<br>AA - 1113 | 300 mm height<br>300 mm height<br>500 mm height<br>800 mm height | 2440 Each<br>4230 Each<br>5020 Each<br>7440 Each |
| 65 |  | <p><i>Crystal</i><br/> <b>Magnetic<br/> Bases<br/> Series-<br/> AA - 160</b></p>  | AA - 1600  | 48 W x 55 H x 65 L mm  | 1200 Each  |
| 66 |  |   | AA - 1601  | 63 W x 75 H x 63 L mm  | 2860 Each  |
| 67 |  | <p><i>Crystal</i><br/> <b>Magnetic<br/> Bases<br/> Series-<br/> AA - 160</b></p>  | AA - 1602  | 56 W x 70 H x 70 L mm  | 2860 Each  |
| 68 |  |   | AA - 1603  | 56 W x 70 H x 65 L mm  | 3150 Each  |
| 69 |  | <p><i>Crystal</i><br/> <b>Magnetic<br/> Bases<br/> Series-AA - 160</b></p>  | AA - 1604  | 48 W x 64 H x 70 L mm  | 2140 Each  |
| 70 |  |   | AA - 1605  | 42 W x 49 H x 49 L mm  | 790 Each   |

# MITUTOYO MAKE

## Magnetic Stand

### SERIES 7

Mitutoyo's Magnetic Stands accept all dial indicators and dial test indicators. The ON-OFF switch offers instant mounting and dismounting without any adverse effect to the indicators or workpiece surface.

#### DIMENSION

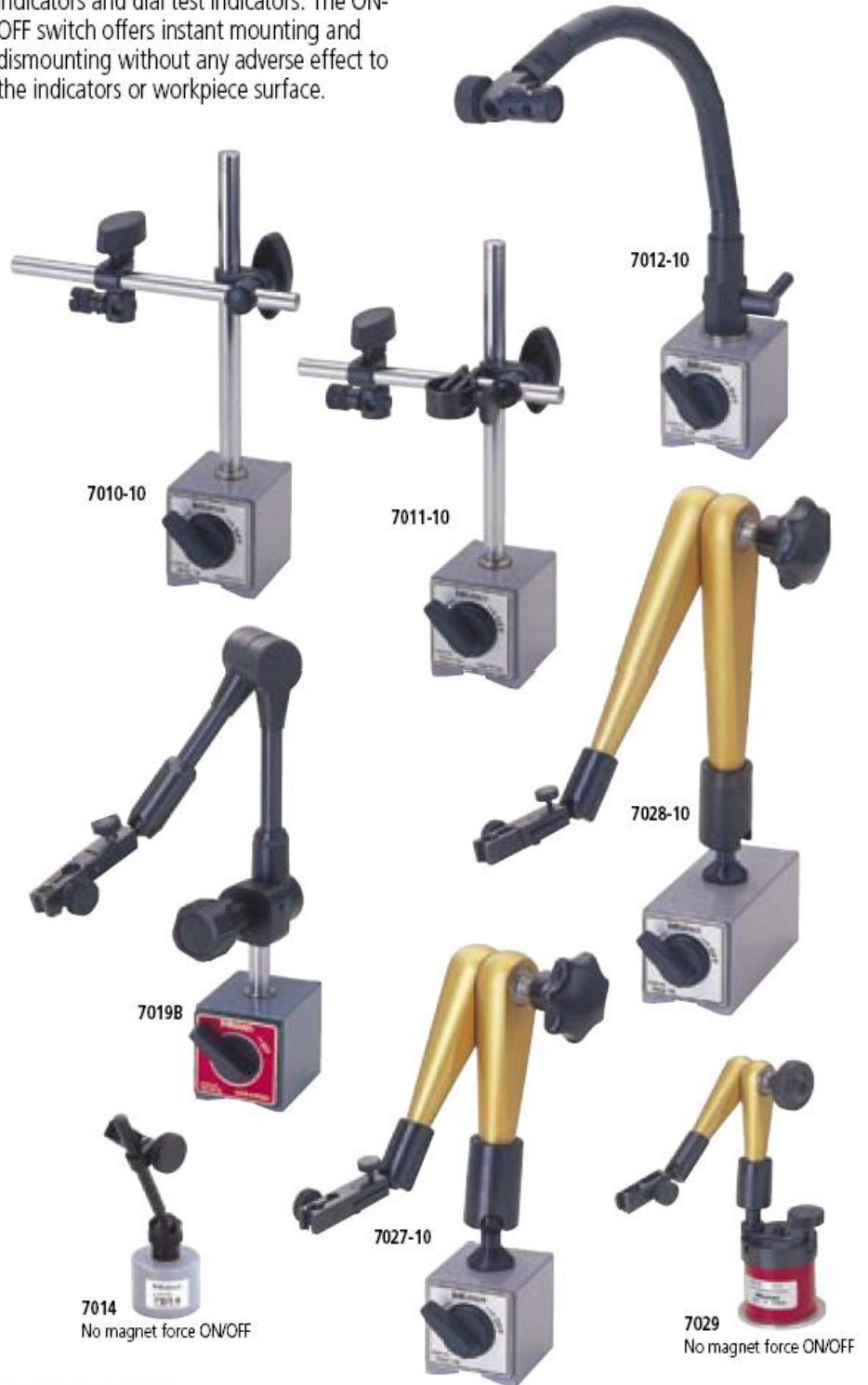
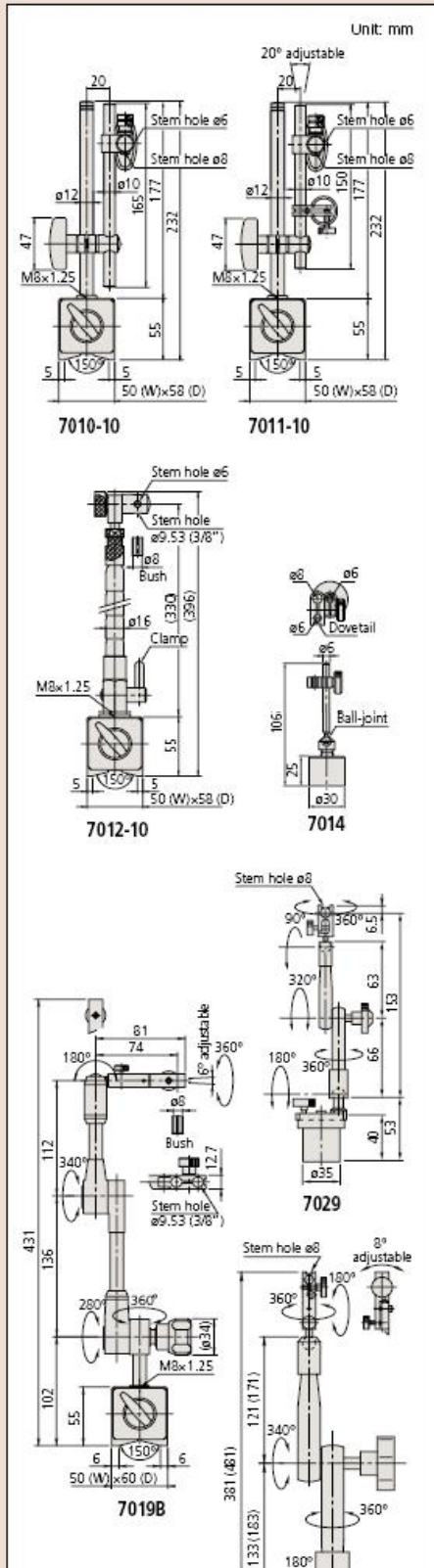

#### SPECIFICATIONS

| Order No. | Description    | Applicable holding stem dia. | Dovetail groove | Remarks |
|-----------|----------------|------------------------------|-----------------|---------|
| 7010-10   | Magnetic stand | $\phi 6$ mm, $\phi 8$ mm     | —               | —       |